

LED Brick Light



LED Brick Light

LED Brick Light uses the latest in “Chip On Board” LED technology to provide a highly effective and energy efficient recessed fixture suitable for indoor and outdoor use. With power consumption of just 5 watts LED Brick Light delivers incredible performance at an affordable price.

The LED Brick Light has been uniquely designed to the specific size of a standard brick. This provides the perfect solution for those applications where a more linear fixture is required.

The warm white (3800° Kelvin) colour temperature provides a natural looking light. Other LED colours to choose from include green, blue, amber and red*.

Choose from 3 decorative cover types – Louvre, Scoop or Prism – each available in 4 colours – white, black, brushed aluminum and bronze.

LED Brick Lights are made of cast aluminum for strength and corrosion protection and are suitable for concrete pour. Each fixture has an available “concrete cap” to make concrete pour installations a breeze.

*white is stock, check availability of coloured LEDs

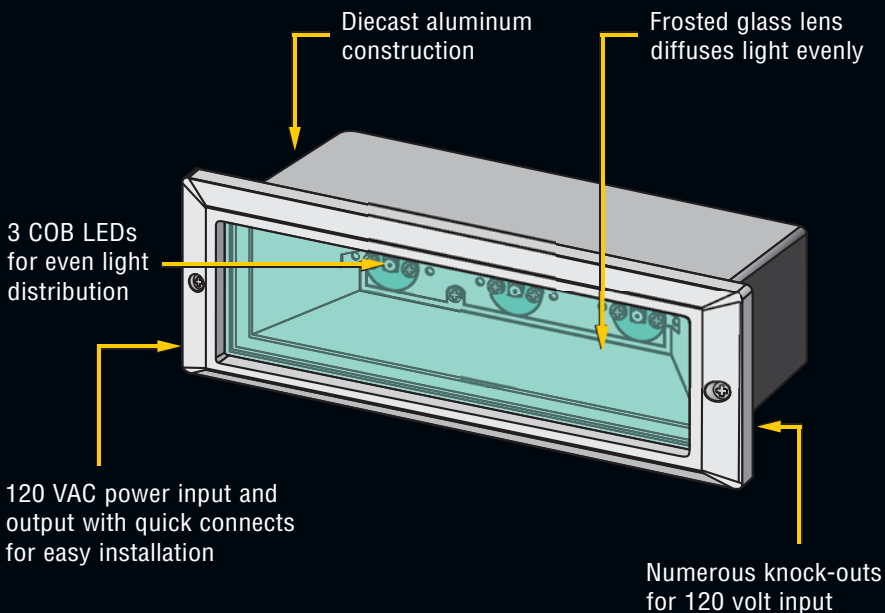

MAGIC LITE LTD.

2526 Speers Road, Unit 4-9
 Oakville, Ontario, Canada L6L 5M2
 Tel: 905-825-9592 • Fax: 905-825-8334
www.magiclite.com

Applications

Interior stairs • Exterior stairs • Aisles • Hallways • Paths • Emergency lighting
 Theaters • Public areas • Patios • Decks – anywhere that requires security or
 safety lighting in an aesthetically pleasing manner!

LED Brick Light

provides a safe, attractive and affordable way to light stairs, aisles, paths and entrance ways



Scoop Cover: White, Black, Bronze, Brushed Aluminum
Cover: 9"W x 3"H x 1.5"D Can: 7.7"W x 2.4"H x 3.2"D



Prism Cover: White, Black, Bronze, Brushed Aluminum
Cover: 9"W x 3"H x .75"D Can: 7.7"W x 2.4"H x 3.2"D



Louvre Cover: White, Black, Bronze, Brushed Aluminum
Cover: 9"W x 3"H x .75"D Can: 7.7"W x 2.4"H x 3.2"D

Why Choose LED Brick Light?

- ✓ Low power consumption – just 5 watts
- ✓ 120 VAC power input and output with quick connects for easy installation
- ✓ Long Life – 60,000 hours
- ✓ Warm colour temperature 3800° K
- ✓ cUL listed for wet and IC locations
- ✓ Suitable for concrete pour*
- ✓ Available concrete cap for easy concrete pour installations
- ✓ Die cast aluminum construction
- ✓ 3 COB LEDs for even light distribution
- ✓ Up to 150 fixtures can be daisy chained on one 15 amp circuit

*IMPORTANT: It is recommended that you use Magic Lite's (XBL, XSL, XWL) Concrete Cap for concrete pour installations. These caps assist in providing a proper reveal for flush mount of fixture cover after concrete is dry.

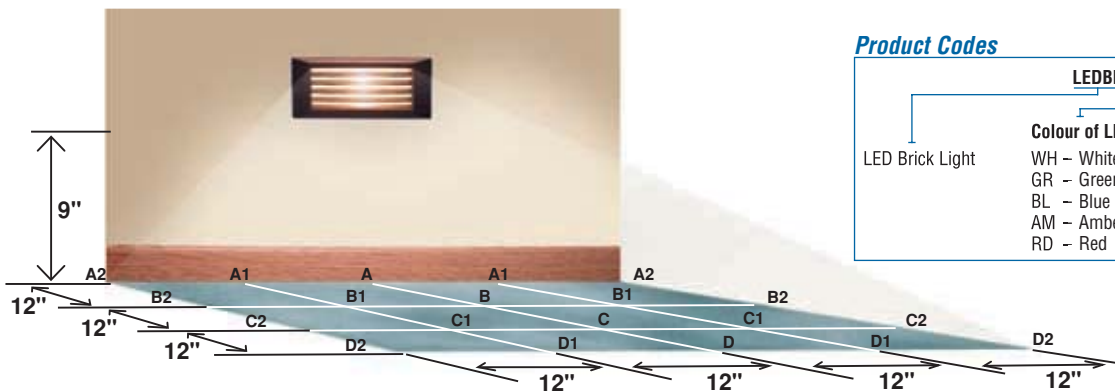
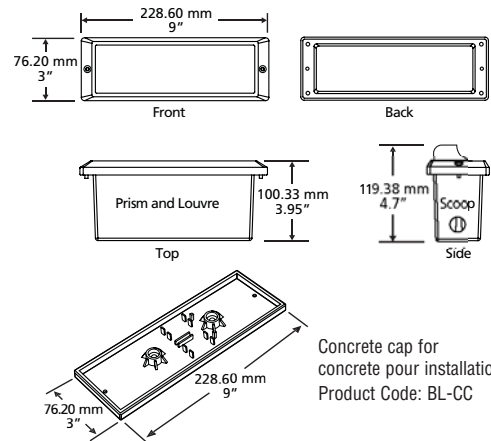

Floor Photometrics

GRID LOCATION:	A	A1	A2	B	B1	B2	C	C1	C2	D	D1	D2
ILLUMINANCE IN FOOTCANDLES:	0	0	0	2.24	0.80	0.15	0.65	0.40	0.17	0.24	0.18	0.10

Product Codes

LEDBL - WH - P - WH			
LED Brick Light	Colour of LED	Cover Type	Cover Finish
	WH - White	P - Prism	WH - White
	GR - Green	S - Scoop	BK - Black
	BL - Blue	L - Louvre	BZ - Bronze
	AM - Amber		AL - Aluminum
	RD - Red		